



Baggage Information

Safe and sound procedures for maximum travel comfort



Hand Baggage Information

For your own safety and comfort, appended below are the carry-on baggage limitations on Malaysia Airlines services:

Piece

First Class and Business Class Passengers	2 pieces
Economy Class Passengers	1 piece

First Class and Business Class passengers are allowed an additional piece of hand baggage of the same dimension.

Dimension

Each piece must not exceed the following dimensions:

Dimension	Length	Height	Width	Total
All aircraft types (B737, B777, B747, A330)	56 cm (22 ins)	36 cm (14 ins)	23 cm (9 ins)	115 cm (45 ins)

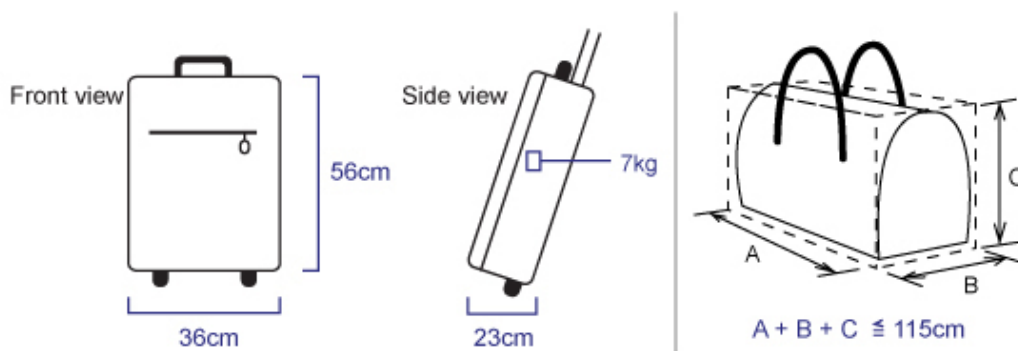

Weight

Each hand baggage must not weigh more than 7 kg.

Hand baggage exceeding the above prescribed dimension and weight or the number allowed, must be checked as check-in baggage



We recommend you take anything you may need on the flight with you, including medication and keys. All medication should have a professional pharmaceutical label on the container if you are transporting medication in your carry-on luggage. If you require a medical syringe, you must have the needle guard intact.

In addition to your carry-on baggage, the following personal items are also allowed as hand baggage:

- A handbag, pocket book or purse.
- A briefcase.
- An overcoat, wrap or blanket.
- Electronic equipment such as laptop, iPad and camera.
- A small camera or a pair of binoculars.
- A reasonable amount of reading material for the flight.
- An infant carry cot.
- Infant and children food for consumption in-flight.
- Fully collapsible baby stroller (on wide body aircraft only).
- Walking stick/canes or crutches and/or braces/prosthetic devices, which the passenger is dependent on.

Malaysia Airlines subscribes to baggage security guidelines recommended by the International Air Transport Association (IATA) and its member airlines. It is the responsibility of all airlines to inform passengers of the importance of these guidelines.

This is why Malaysia Airlines has placed great importance on the control of carry-on baggage. Keeping an eye on the number and size of bags allowed on board means that our passengers will enjoy the comfort of a well-kept cabin, free of any inconvenience and hazards, because:

- There is ample storage space for all passengers' hand baggage. Movement into and out of seats is easier.
- Departure and arrival will be on time as there is improved passenger boarding and disembarkation.
- Cabin crew service along the aisle is smoother.
- Transfers between flights are faster.
- Emergency evacuation becomes easier.

Carry-on baggage must be stowed underneath the seat in front of the passenger or in the overhead compartment. Please note that security items such as knives, nail clippers, blades, or any sharp and/or pointed objects must be removed from carry-on baggage and packed in checked baggage. You must be able to activate any electronic devices (e.g. CD players, laptops, video cameras) at the security checkpoint. If you are unable to do so, you must pack these items in your checked baggage.

Electrical devices

Prior to departure, you will be allowed to use your Portable Electronic Device (PED) including cellular telephones up to the time when all the aircraft doors are closed. After landing, you are permitted to use your Portable Electronic Device (PED) after any one of the aircraft doors is opened.

However, to prevent fire hazards, all electronic devices are to be switched off during refueling operations. Please note that if you are travelling with electronic items as part of your carry-on baggage, you will be expected to demonstrate that the device is operational at security checkpoint. If you do not have a power source for your electronic item, please ensure you pack your electronic item as checked baggage.



Examples of items not permitted beyond the screening checkpoints

- All knives, cutting and puncturing instruments including box cutters, ice picks, straight razors, metal scissors, metal nail files and corkscrews;
- Any sharp and/or pointed objects;
- Weapons including handguns, rifles, ammunition, gun powder, pepper spray, bear spray, mace, tear gas, replica or toy weapons;
- Aerosol spray cans including hair spray, deodorant, insect repellent, or butane fuel;
- Balloons filled with helium gas;
- Flammable liquids or solids including fuel, paint, paint thinner, lighter fluid;
- Sporting equipment such as: golf clubs, lacrosse sticks, hockey sticks, ski poles, squash/tennis racquets, ice skates, baseball/softball bats, pool cues;
- Any other hazardous item as defined and regulated by law including explosives, fireworks, radioactive materials, poisons, infectious substances;
- Umbrellas are not allowed to be carried on board as the shape resembles a weapon in some instances.

For Your Convenience

Before proceeding to the departure area, please check and ensure that your hand baggage quantity, weight and dimensions meet the recommended guidelines.

The airport authorities have placed hand baggage test kits at check-in counters and at the entrance to departure halls. Please use these kits to ensure that your hand baggage size conforms to the stated measurements.

If your hand baggage does not conform to the size specified, the airport authorities or airline personnel will disallow entry into the departure area. You will then have to return to the check-in counter.

Should you need further assistance, please consult our airline passenger handling staff or your travel agent.



Baggage Check-In

When you check-in, you may be asked some questions about your baggage:

- Has your luggage been in your possession at all times?
- Are you aware of the contents in your bag?
- Are you aware, these dangerous goods are not permitted in your bag? (See below)

Dangerous Goods

International Air Transport Association (IATA) defines Dangerous Goods as articles or substances that are capable of posing a risk to health, safety, property, or the environment when they are transported. As a general rule, passengers are not permitted to transport dangerous goods on board an aircraft in their carry-on baggage or checked baggage.

Your check-in baggage must not contain hazardous materials, including explosives, compressed gasses, flammable liquids and solids, oxidizers, poisons, corrosive, radioactive materials and damaged lithium battery.

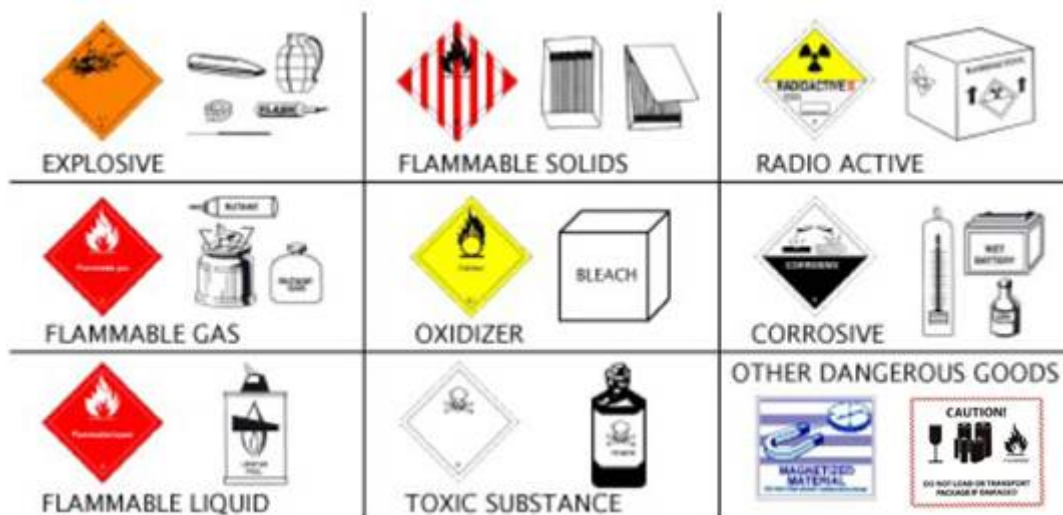

All checked baggage must have your name, address and telephone number or email on the outside of the bag. You are strongly encouraged to put your name and address on the inside of the bag as well should the outside tag be separated from the bag. Malaysia Airlines may refuse baggage at check-in unless it is labeled.



Excess Value Declarations and Charges

You may declare a value for your checked baggage in excess of the applicable liability limit. If you make such a declaration, you must pay additional charges in accordance with our regulations.

Malaysia Airlines will not accept liability for valuables, fragile or perishable articles including money, jewellery, cameras, video and electronics equipment, silverware, negotiable instruments, business documents, samples, antiques, paintings, furs, manuscripts or similar items, computers and medication.

Checked Baggage Allowance

The amount of checked baggage that you can take with you free of charge is determined according to either the number of pieces or the weight. The 'allow' box on your paper ticket indicates which of these concepts apply to your baggage allowance. On your e-ticket, this is indicated in the 'baggage' box.

Weight System

(All destinations except to and from Americas)

The table below states the maximum weight of the checked baggage that you can take with you free of charge.

Locations	Class	Maximum Free Baggage Allowance Weight
All locations except Americas (North and South Americas)	First	40 kg (88 lbs)
	Business	30 kg (66 lbs)
	Economy	20 kg (44 lbs)
	Infants (on 10% tickets)	<ul style="list-style-type: none"> One bag maximum dimensions 45 inch (115cm), which may be carried as cabin baggage, and One fully collapsible baby pushchair or stroller or carrying basket <p>The weight of the allowed items may not exceed 10 kg (22 lbs) in total</p>

A charge at the appropriate journey rate per kilogram will apply for any baggage carried in excess of the free baggage allowance as above.



**Piece System
(To and from Americas)**

For passenger travel to and from North Americas and South Americas, the baggage allowance will be based on Piece system. Each passenger is allowed to check-in 2 pieces of baggage regardless of class of travel.

The table below states the maximum weight for each piece of checked baggage and maximum outside linear dimension for the checked baggage according to the class of travel.

Locations	Class	Maximum Weight Per Piece	Maximum Outside Linear Dimension
To and from North and South Americas	First & Business	32 kg (70 lbs)	158 cm (62 ins) each piece
	Economy	23 kg (50 lbs)	269 cm (107 ins) for 2 pieces
	Infants (on 10% tickets)	<ul style="list-style-type: none"> One bag maximum dimensions 45 inch (115cm), which may be carried as cabin baggage, and One fully collapsible baby pushchair or stroller or carrying basket <p>The weight of the allowed items may not exceed 10 kg (22 lbs) in total.</p>	

Baggage in excess of the checked baggage allowance is charged per piece. Contact your local Malaysia Airlines Office for details on charges.

Restrictions to Weight of Single Piece of Checked Baggage on all Malaysia Airlines Services

To comply with Global Health and Safety regulations for baggage handlers, Malaysia Airlines has imposed a strict ruling to ensure that each single piece of item or baggage that is checked-in DOES NOT exceed 32 kg (70 lbs).

Irrespective of class of travel, any single piece of baggage weighing more than 32 kg (70 lbs) will not be accepted at check-in counters at any station. Customers will be required to reduce the weight by repacking the baggage into smaller units before they are allowed to check-in. This regulation equally applies to transit baggage.

We recommend that items exceeding 32 kg (70 lbs) such as bulky musical instruments, sports equipment, as well as photo and film camera equipment should be sent through MASKargo, our cargo service.

Customers can still check-in their bulky musical instruments, sports equipment, photo and film camera equipment as checked baggage but the items must be properly packaged in protective bags or wrap and subject to applicable overweight and oversize baggage charge. Acceptance depends on the capacity of the (various) aircraft operating on the passenger’s routing. If the baggage cannot be accommodated on one of the aircraft, it cannot be accepted for the whole route.



a. For some types of special baggage advance reservations should be made. Malaysia Airlines may refuse acceptance if deemed necessary.

b. If accepted, the passenger must pack the baggage in such a way that the item and/or its contents are sufficiently protected to endure ordinary handling.

c. Limited liability may apply for checked-in special baggage.

We recommend that items exceeding 32 kg (70 lbs) such as bulky musical instruments, sports equipment, photo & film camera equipment etc. should be sent through MAskargo, our cargo service.

Carriage of Domestic Pets

The carriage of domestic pets in the aircraft cabin is not permitted. Domestic pets may however be uplifted in the cargo holds on the same flight as special excess baggage, subject to certain conditions.

Pets in the Baggage Compartment

Live animals classified as pets such as cats, dogs and fishes may be accepted as accompanied baggage at check-in provided:

- Individual countries health and governmental regulations are complied.
- Customs import/export permits for carriage may be required.
- Veterinarian Health Certificate for the animals may be required.
- The accepted animals are stowed in aircraft holds.
- The weight of the animal and its container/cage will be charged as excess baggage. It is not accepted as part of free baggage allowance.
- The instruction for feeding and watering must be given in writing at the time of acceptance.

Reservations are required to be made with a Malaysia Airlines Reservations Agency.

The container or kennel used for the animals must satisfy the following conditions:

- Constructed and be able to withstand other freight damaging it or causing the structure to buckle or bend.
- Adequately ventilated on at least three sides, with the majority of the ventilation being provided on the upper part of the container.
- The ventilation openings must be small enough or covered with mesh in order to prevent escape or any part of the animal protruding with the resultant danger of injury.
- It must allow the animal to stand, turn and lie down in a natural manner.
- Separate food and water troughs must be provided, either fixed inside the container or attached to it so that they are accessible for replenishment purposes.
- It must be clean and leak-proof.
- Have layers of absorbent materials on its floor to prevent soilage and damage to aircraft floor.
- It must be easy for staff to handle and provide the handlers protection from being clawed or bitten by the animal.



Musical Instrument

Malaysia Airlines is pleased to accept musical instruments (both electrical and nonelectrical) for carriage as checked baggage. It must be securely packed. The musical instrument and container is subject to the applicable oversized baggage charge.

Small musical instruments may be allowed as carry-on baggage, even if the item may not fit into the baggage-sizing unit due to its irregular shape.

Sporting Equipment

All sporting equipment must be properly packaged in protective bags or wrap.

Archery Equipment

Archery equipment is accepted as part of free baggage allowance. If excess of the Free Baggage Allowance, it is subject to excess baggage charge. Archery equipment is defined as one or a combination of the following:

- one bow;
- one quiver containing arrows;
- a maintenance kit

The items must be encased in a container of sufficient strength to protect the items from damage.

Bookeyboards

One boogeyboard, with overall dimensions not exceeding 62 inches, is accepted as part of free baggage allowance. If excess of the Free Baggage Allowance, it is subject to excess baggage charge.

Bowling Equipment

Bowling equipment is accepted as part of free baggage allowance. Bowling equipment is defined as one or a combination of the following:

- one or two bowling balls
- one bowling bag
- one pair of bowling shoes

Items in excess of Malaysia Airlines' free baggage allowance will be assessed an excess baggage charge.



Bicycles

Non-motorised touring or racing bicycles with single seats for carriage are accepted as checked baggage with certain limitations.

Any bicycle presented for carriage must be packaged in one of the following ways:

- Handlebars are fixed sideways and pedals removed and enclosed in a cardboard container;
- Pedals and handlebars encased in plastic, styrofoam, or other similar material.

Any bicycle presented in a box with overall dimensions not exceeding 62 inches and checked in lieu of one bag is accepted. In addition, 2 baggage systems with 2 conditions each, will apply accordingly:

Weight System (all destinations except to/from Americas)	Piece System (to/from Americas)
For passengers travelling between Europe & Asia	For passengers travelling across Atlantic or Pacific
Bicycle will be accepted as checked baggage provided that handlebars are fixed sideways and the pedals are removed.	Bicycle will be accepted as part of 2 pieced free checked baggage at 23kg each.
It will be treated as any other piece of baggage, subject to excess baggage charge if weight exceeds free baggage allowance.	It will be treated as any other piece of baggage of up to 23kg each and subject to excess baggage charge.

Note: Some connection carriers and aircraft may not accept bicycles as checked baggage, and may have different limitations.

Some Malaysia Airlines stations have fixed rates for bicycles especially from European airports. The carriage of bicycle will not be included in the checked baggage allowance and shall be accessed as a single item:

- One bicycle up to a maximum weight of 15 kg at a fee of EUR 70 return and EUR 35 one way ex Europe.
- One bicycle up to a maximum weight of 32 kg at a fee of EUR 150 return and EUR 75 one way ex Europe.
- One bicycle up to a maximum weight of 15 kg at a fee of GBP 70 return and GBP 35 one way ex London.
- One bicycle up to a maximum weight of 32 kg at a fee of GBP 150 return and GBP 75 one way ex London.



Canoes/Kayaks

Canoes and Kayaks are not accepted as checked baggage. To be accepted strictly as cargo. Please contact MASkargo for your shipping needs.

Fishing Equipment

One item of fishing equipment is accepted as part of free baggage allowance. One item of fishing equipment is defined as one or a combination of the following:

- two rods
- one reel
- one landing net
- one pair of fishing boots (all properly encased)
- one fishing tackle box

Items in excess of Malaysia Airlines' free baggage allowance will be assessed an excess baggage charge.

Golfing Equipment

One item of golfing equipment is defined as one or up to all of a combination of the following:

One golf bag containing not more than;

- 14 golf clubs
- 12 golf balls
- one pair of golf shoes

Weight System (all destinations except to/from Americas)	Piece System (to/from Americas)
Applicable for travel between points in Area 2 and Area 3, points within Area 2 and points within Area 3.	Applicable for travel between points in Area 1 and Area 2/3 and points within Area 1.
One item of golfing equipment with a maximum weight of 15kg will be carried free. Any subsequent sets will be carried for free if the total weight of checked in baggage (excluding the 1st golf set) is within free baggage allowance	One set of golfing equipment will be assessed 50% of the applicable charge for a single piece. Additional sets will assess the full applicable excess charge for a single piece.

Customers wishing to check golf clubs have two options:

1. Hard shell golf travel containers - no limited liability release required
2. All other golf travel bags (i.e., soft-sided bags) - limited liability release required

The limited liability release absolves Malaysia Airlines of responsibility for preexisting damage to the clubs or damage from the normal course of handling.

Info: IATA Areas

The International Air Transport Association, for administrative purposes, divides the world into three IATA Traffic Conference Areas.

These are referred to as Areas No. 1, 2 & 3.

- IATA area 1 comprises of the North and South American Continent and adjacent islands.
- IATA area 2 comprises of all Europe, Iceland and Africa.
- IATA area 3 comprises of all Asia and Australia and New Zealand.



Parachutes

Hang gliders will only be accepted if they are within the maximum dimensions of 3m x 1.00m x 0.80m (118in x 39in x 31in).

If item in excess of the FBA, the normal excess baggage rate applies.

Sport parachutes are accepted under the rules and procedures for carry-on baggage provided no items classified as dangerous goods (example: pressurized oxygen cylinders) are included.

Scuba Diving Equipment

Scuba diving equipment will be accepted as checked baggage and will always be subject to an excess baggage charge.

One item of Scuba Diving Equipment is defined as:

- One scuba tank (empty)
- One scuba regulator
- One tank harness
- One tank pressure gauge
- One mask
- Two fins
- One snorkel
- One knife
- One spear gun
- One safety vest

1. Piece System (to/from Americas)

Items of scuba diving equipment will be subject to excess baggage charge for a single piece whether or not presented as a single piece. Regardless of actual dimensions will be considered to be one piece of baggage whose outside linear dimensions are 62 inches.

100% or single charge of the applicable excess baggage charge

Exception: (Applicable for travel between Canada/USA and Malaysia only.)

One item of scuba diving equipment will be included in determining the FBA, when in excess, such equipment will be assessed 50% of the applicable charge for a single piece.

Additional sets will be assessed the full applicable excess baggage charge for a single piece.

2. Weight System (all destinations except to/from Americas)

Scuba diving equipment shall be included in the Free Baggage Allowance (FBA). Please note that tank has to be empty.

10kg weight allowance will be given in addition to normal FBA. Any overweight after takes into account the extra 10kg, normal excess baggage rate will be charged.



Skiing Equipment

Skiing equipment will be accepted as checked baggage and will always be subject to an excess baggage charge.

Normally we will define an item of skiing equipment as being:

- one pair of skis, one pair of ski poles, one pair of boots, or
- one snowboard, one pair of boots, or
- one pair of standard water skis or one slalom water ski

If excess of the Free Baggage Allowance, skiing equipment is subject to a special charge as follows:

Weight System

For most destinations, your skiing equipment can be included in the free baggage allowance. If the total weight for check-in baggage and skiing equipment exceed the free baggage allowance, excess baggage will be charged. We have developed a special charge that limits the charges to a maximum of 3 kg for one item of skiing equipment only. Any additional item, the normal excess baggage rate shall apply.

Piece System

If you're flying to and from North and South America and Nigeria, the charges for one item of skiing equipment if exceed the free baggage allowance shall be 33% of the applicable excess baggage rate. Any additional item, the normal excess baggage rate shall apply.

Surfboards

One surfboard/windsurfing to a maximum length of 3 meters (118 inches) will be accepted as checked baggage provided the item is in a protective case and will always be subject to an excess baggage charge. Items over 3 meters in length shall not be accepted as checked baggage.

Additional surfboard restrictions and exceptions:

- If not presented in a protective case, the item will only be accepted upon completion of a Limited Release tag.
- Fees may vary per carrier or destination.

What is an LRT baggage tag?

A Limited Release Tag or LRT is a special type of baggage tag that is attached to non-standard pieces of luggage such as strollers and sporting equipment. This includes baggage, which is oversized, fragile, perishable, or unsuitably packed, bags presented damaged at check-in, security removed items and bags checked in late, which might not be loaded on the flight. LRTs releases the airline from liability should this item become damaged.



Packing Tips

- Always remove the previous trip airline tags and mark your baggage with your name, address, email and contact number where you can be reached at your destination. You should also put a copy of this information inside your baggage. Should your baggage be misplaced, these labels will hasten identification and help us to return it to you. Labels can be obtained at the Malaysia Airlines check-in counter.
- Mark your bags with a brightly coloured string or ribbon to assist you in identifying your bag quickly on the baggage carousel.
- Keep all loose handles, hooks, and straps closed securely inside if you can, or remove them. These can catch on conveyers and belt loaders and cause damage to your luggage or other passengers' luggage.
- Always lock your baggage.
- For security reasons, ensure you pack your bags yourself and do not at any time leave them unattended. Never carry a package or baggage for someone else unless you have completely checked the contents.
- Due to safety requirements, there are a number of items that cannot be packed in your carry-on or checked baggage. Please visit dangerous goods information above.
- Never wrap or package gifts; security personnel may need to inspect them.
- Keep medication and fragile items in your carry-on baggage. Keep all medication in its original, labelled container and carry the physician's prescription with you.
- You must be able to activate any electronic devices at the security checkpoint. If you are unable to do so, you must pack these items in your checked baggage.
- When you check your bags, make sure you get the correct number of luggage claim stubs and that each one is marked with the correct city name of your destination on your luggage tags.
- Make a list of items you have packed and their estimated value. Keep your list in a safe place until you return. Report any missing, delayed or damaged items before you leave the airport. This will help us to start tracing right away.
- Malaysia Airlines advises you that following items may not be included in your baggage and it accepts no liability for your damage or loss:
 - Cash, negotiable bonds, deed, etc;
 - Jewellery, antiques or similar valuable items;
 - Any item of a fragile or brittle nature (e.g. glassware);
 - Electrical or electronic components (e.g. computer, camera, mobile phone, audio equipment);
 - Food or any perishable item;
 - Any item that has insufficient packaging (e.g. surfboard, bicycle, musical instrument).